



# PAROC<sup>®</sup> REFACE<sup>™</sup> TECHNICAL GUIDE

PAROC<sup>®</sup> panel solutions

August 2017

# CONTENTS

<b>1</b>	<b>PAROC® REFACE™ PANELS</b>	
	1.1 PRODUCT DESCRIPTION .....	3
	1.1.1 Suitability of PAROC® Reface™ panels on top of existing wall structures...	3
	1.1.2 Installation direction effect on drying capacity .....	4
	1.1.3 Installation options for PAROC® Reface™ panels .....	4
	1.1.4 Installation details of PAROC® Reface™ panels .....	4
	1.2 FACINGS .....	5
	1.2.1 PVDF coating for exterior surfaces.....	5
	1.2.2 Polyester coating for interior surfaces .....	5
	1.3 CORE .....	5
	1.4 PAROC® REFACE™ PANEL TYPE .....	5
	1.5 PANEL PERFORMANCE .....	6
	1.6 THERMAL INSULATION .....	7
	1.6.1 U-value for the wall structure .....	7
<b>2</b>	<b>DIMENSIONING</b>	
	2.1 GENERAL .....	8
	2.1.1 Vertical loads .....	8
	2.1.2 Support width .....	8
	2.2 EXTERNAL WALLS .....	10
	2.2.1 Loads for external walls.....	10
	2.2.2 Spans for single-span external walls.....	10
	2.2.3 Walls with multi-span panels.....	10
	2.3 DEFLECTION .....	20
	2.4 OPENINGS AND CUT-OUTS .....	22
	2.5 DIMENSIONING EXAMPLE.....	23
<b>3</b>	<b>MOUNTING PANELS</b>	
	3.1 PANEL FIXINGS.....	25
	3.2 FASTENING OF WALL PANELS.....	25
	3.2.1 Fastening with penetrating panel fixings.....	25
	3.4 FIXING OF FLASHINGS .....	26
	3.5 SUSPENSIONS.....	26
	3.5.1 Forces .....	26
	3.5.2 Allowed loads.....	26
<b>4</b>	<b>APPROVALS AND CERTIFICATES</b> .....	31

The technical specifications and recommendations in this Technical Guide are based on the applicable sections of the standard EN 14509 “Self-supporting double skin metal faced insulating panels”. The design must comply with national standards.

Paroc Panel System will only be held liable for the panel properties listed in this Technical Guide. Other information on identifying loads, dimensioning, detailed planning, installation etc. is only intended as a guide.

The latest version of this Technical Guide will always be published on our website. Read more about detailed solutions for PAROC® panel structures on our website.

[www.paroc.com/panelsystem](http://www.paroc.com/panelsystem)

# 1 PAROC® REFACE™ PANELS

## 1.1. PRODUCT DESCRIPTION

PAROC® Reface™ panels are diffusion-open light weight sandwich panels, which are developed for renovation purposes. The panel surfaces are made of steel sheet and the core is made of PAROC structural stone wool, which includes ventilation channels designed to eliminate moisture. The thermal and moisture-related technical functionality of PAROC Reface panels is achieved through a diffusion-open interior sheet and an airtight and vapour-permeable foil. The strength and durability of the panels are based on the integration of the surface sheets, the core and the adhesive bonds. VTT Technical Research Centre of Finland Ltd has performed calculations on the thermal and moisture-related technical functionality of PAROC Reface panels (VTT-S-03716-15 and VTT-S-01757-16). PAROC Reface panels are non-combustible in accordance with the A2-s1,d0 Euroclass classification (EN 13501-1).

### 1.1.1 SUITABILITY OF PAROC® REFACE™ PANELS ON TOP OF EXISTING WALL STRUCTURES

When planning renovation work on an existing structure, the first step is finding out the condition the existing structure is in and whether there is any damage to it. The causes of any damage must be identified, and it must be ensured that these are rectified during the renovation. In order to find out the condition of an existing structure, Paroc Panel System recommends an expert consultation to ensure the best possible quality and functionality.

The installation of a PAROC® Reface™ panel on the exterior surface of an existing structure necessitates a review of the factors mentioned below and any necessary repairs to the existing structure, among other things:

- Any damage to the existing structure and related causes have been identified and these can be eliminated during the renovation process.
- The air tightness of the existing structure is adequate or can be renovated to adequate level.
- The pressure of the indoor air in the building is primarily negative, also in the upper parts of the building (e.g. at ceiling joints).
- The humidity of the indoor air is equivalent to or less than that of a dry living space.
- Any microbial growth in the existing wall structure must be removed from areas that are critical to the quality of the indoor air.
- A construction professional should produce a report focusing on the structural physics of the existing structure and the PAROC® Reface™.

Fig. 1. Components of a PAROC® Reface™ panel

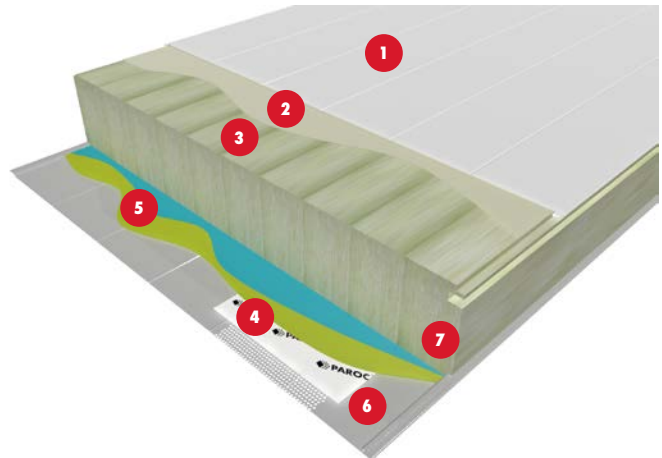

- 1 Exterior facing: sheet steel with zinc coating and an outer coating that complies with the requirements of the surrounding conditions.
- 2 Specially developed adhesive which complies with the AST® quality requirements concerning strength and durability.
- 3 Non-combustible (A1) PAROC structural stone wool core with ventilation channels.
- 4 Windshield foil that allows water vapour to pass through it in a diffusion-open area, improving the airtightness of the structure.
- 5 Specially developed adhesive which complies with the AST® quality requirements concerning strength and durability.
- 6 Interior facing – a substrate-coated hot dip galvanised steel sheet as a diffusion-open structure.
- 7 Fire-resistant tongue-and-groove structure and seals in both tongues and grooves.

The strength, durability and fire resistance of the sandwich panels are guaranteed by their AST® quality (Advanced Structural Technology) grade. These important qualities are not visible to the naked eye, but they can be measured and tracked as part of the production process. PAROC prefabricated panels fully comply with the AST® quality requirements.

An example of a site before and after renovation: Sâma AB in Uppsala, Sweden.



1.1.2 THE EFFECT OF INSTALLATION DIRECTION ON DRYING CAPACIT

PAROC® Reface™ prefabricated panels can be installed either horizontally or vertically. The installation method should be chosen based on the condition of the existing structure, spans, appearance and functionality. When installing panels vertically, the channel ventilation is approximately 7 times more effective than when installed horizontally (with a panel thickness of 50 mm).

The ventilation effectiveness of horizontally fitted panels is inferior to that of panels installed vertically. Therefore, the initial moisture of all structures may not exceed 80% RH before installing panels horizontally. Paroc Panel System recommends that the moisture of existing structures be identified before selecting an installation method.

If the moisture level of the structures is extremely high, an initial drying process should be carried out by leaving a temporary ventilation gap between the existing and the new wall. This temporary ventilation gap is to be sealed when the existing structure has dried sufficiently. In these cases, Paroc Panel System recommends the introduction of real-time moisture and temperature monitoring. Paroc Panel System will provide guidance and assistance when necessary.

1.1.3 INSTALLATION OPTIONS FOR PAROC® REFACE™ PANELS

PAROC® Reface™ panels may be installed on to an existing wall in three different ways. The choice of installation method is based on the evenness and strength of the existing structure, the spans and the thickness of the panel used, as well as other factors.

1.1.4 INSTALLATION DETAILS OF PAROC® REFACE™ PANELS

The installation details are available in PDF and DWG files at [www.paroc.com/reface](http://www.paroc.com/reface)

Fig. 2. Vertical installation

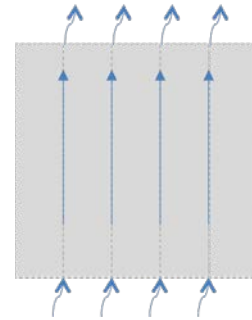

Ventilation channels in a vertical installation

Fig. 3. Horizontal installation

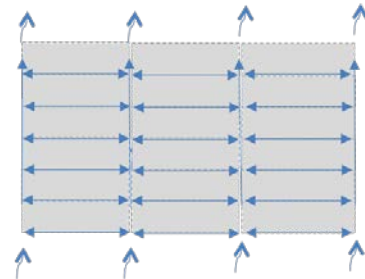

Ventilation channels in a horizontal installation.

Table 1. Installation options of PAROC® REFACE™ panels.

Installation directly onto an existing structure	Installation with a support framework	Installation with an adjustable framework
<b>Surface:</b> Even	<b>Surface:</b> Somewhat uneven	<b>Surface:</b> Significantly uneven
<b>Thickness of the structure:</b> panel 50–300 mm	<b>Thickness of the structure:</b> panel 50–300 mm + 25 mm framework	<b>Thickness of the structure:</b> panel 50-300 mm + adjustable framework 52-82 mm

## 1.2 FACINGS

The facings of PAROC® Reface™ panels consist of a substrate coated hot dip galvanised steel sheet, which is zinc-coated on both sides to ensure that the steel is resistant to corrosion.

The sheet is also primed to improve the adhesion of the substrate coating to the steel. The exterior surface of the steel sheet is coated with plastic, and the interior surface has been prepared to ensure maximum adherence of the sheet to the core.

Fig. 4. PAROC Reface panel facing layers.

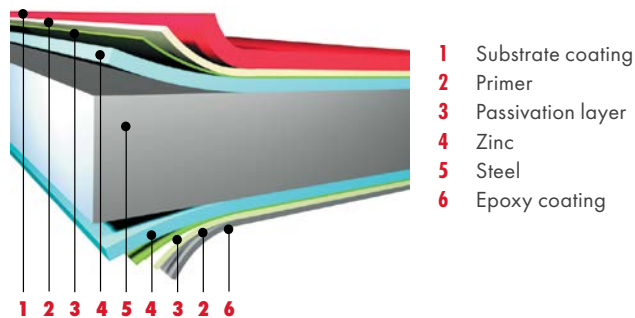

The standard thickness of the steel sheet is either 0.5 mm or 0.6 mm. The thickness of the sheet is usually decided as follows:

- 0.6 mm for exterior surfaces of external walls
- 0.6 mm for perforated surface of the PAROC Reface panels

We are able to provide sheets with custom thicknesses by request. The standard coatings are PVDF and polyester.

The standard selection of colours can be found in the Colours brochure. The hot-galvanised uncoated steel sheet is used especially in high temperatures.

### 1.2.1 PVDF COATING FOR EXTERIOR SURFACES

We recommend choosing a PVDF coating for regular outdoor use. It is highly resistant to strain caused by dirt and UV radiation, which means that the colour does not fade easily.

### 1.2.2 POLYESTER COATING FOR INTERIOR SURFACES

A polyester coating (SP) may be used to interior and exterior surfaces, though it is better suited to indoor use.

Table 2. Coating properties.

Property	Coating			
	PVDF	PVDF HB	PVDF (MATT)	SP
Material	polyvinylidene fluoride	polyvinylidene fluoride	polyvinylidene fluoride	polyester
Range of Application	Exterior	Exterior	Exterior	Interior/Exterior
Coating thickness, µm	27	40	26	25
Surface	Smooth	Smooth	Structured	Smooth
Maximum service temperature °C <sup>1)</sup>	110	110	110	90
Recommended environmental category <sup>2)</sup>	C3	C4	C3	C3
Appearance stability	Excellent	Excellent	Excellent	Good
Gloss – Gardner 60°	30–40 <sup>4)</sup>	3–5	3–5	30–40

<sup>1)</sup> Refers to continuous operating temperature.

<sup>2)</sup> Environmental category according to EN ISO 12944-2:1998.

<sup>3)</sup> The corrosion category should be chosen on a case-by-case basis.

<sup>4)</sup> The gloss of metallic colour options is slightly lower.

## 1.3 CORE

PAROC structural wool is a type of specially developed wool with fibres uniformly aligned, guaranteeing controlled strength properties. It is water repellent and lacks hygroscopic or capillary properties, so the wool does not absorb any water. The durability of the core wool and its binder is not affected by moisture. Several types of PAROC structural wool are available.

### 1.4 PAROC® REFACE™ PANEL TYPES

There are three distinct PAROC® Reface™ panel types, each with different technical properties. A suitable panel type is chosen according to applicable strength and thermal insulation capacity requirements:

- **AST® L** should be used for external walls with high thermal insulation capacity requirements.
- **AST® S** should be used for regular external walls.
- **AST® E** should be used for walls with high strength requirements.

## 1.5 TECHNICAL PROPERTIES OF THE PANELS

*Table 3. Technical properties of PAROC® Reface™ panels.*

### EXTERNAL WALLS

Panel Type	Property	Property								
		50	80	100	120	150	175	200	240	300
	Nominal thickness, mm	50	80	100	120	150	175	200	240	300
	Actual thickness, mm	53	79	99	120	151	173	202	243	305
AST® L	Thermal resistance R, m <sup>2</sup> K/W <sup>1)</sup>	N/A	2.09	2.61	3.14	3.93	4.59	5.24	6.3	7.87
	Weight, kg/m <sup>2</sup> <sup>2)</sup>	N/A	15	17	18	21	22	24	27	31
AST® S	Thermal resistance R, m <sup>2</sup> K/W <sup>1)</sup>	N/A	1.98	2.48	2.98	3.73	4.36	4.98	5.98	7.48
	Weight, kg/m <sup>2</sup> <sup>2)</sup>	N/A	17	19	21	23	25	28	32	37
AST® E	Thermal resistance R, m <sup>2</sup> K/W <sup>1)</sup>	1.09	1.76	2.2	2.65	3.31	3.87	4.42	5.31	6.65
	Weight, kg/m <sup>2</sup> <sup>2)</sup>	16	19	22	24	28	31	34	39	47

“N/A” means that the product is unavailable.

- <sup>1)</sup> The thermal resistance value R (m<sup>2</sup>K/W) takes into account the effect of PAROC® Reface™ panel ventilation channels and the effect of end joints on the thermal insulation capacity of the panel.
- <sup>2)</sup> Applicable to panels with standard facings.

**The maximum length** of a panel is 12 m. However, this may be limited in practice to ensure easy and safe handling of the panel. **The modular width** is 1200 mm and the cover width is 1196 mm. **Panel tolerances** are as follows:

- Panel length ±5 mm
- Panel thickness ±1 mm
- Panel cover width ±2 m

## 1.6 THERMAL INSULATION CAPACITY

### 1.6.1 STRUCTURE U-VALUE

The thermal insulation capacity of PAROC® Reface™ panels is determined by panel ventilation channels, the installation method (horizontal or vertical installation) and whether the panels are installed with or without a framework. Table 4 takes into account the effect ventilation channels have on the thermal resistance of the panels.

The U-value of a renovated wall can be calculated based on the thermal resistance value of both the existing wall and the PAROC Reface panel and the surface resistance values. Three different types of PAROC® Reface™ prefabricated panels are available, with a choice of nine different thicknesses. The effect of penetrating panel fixings must be taken into account when determining the U-value of the entire wall.

**Table 4.** Thermal resistance of the panels  $R$  ( $m^2 K/W$ )

Panel Type	W/mK	50 mm	80 mm	100 mm	120 mm	150 mm	175 mm	200 mm	240 mm	300 mm
AST® L	0.038	N/A	2.09	2.61	3.14	3.93	4.59	5.24	6.3	7.87
AST® S	0.040	N/A	1.98	2.48	2.98	3.73	4.36	4.98	5.98	7.48
AST® E	0.045	1.09	1.76	2.2	2.65	3.31	3.87	4.42	5.31	6.65

“N/A” means that the product is unavailable.

Please contact the sales department of Paroc Panel System to calculate a new U-value for your specific needs. In addition, the effect of additional airtightness can be assessed.

**Table 5.** Influence of fixing screws  $\Delta U_f$ . The amount of screws is 0.7 pcs/m<sup>2</sup> ( $\varnothing$  6.3 mm).

Material	$\Delta u_f, w/m^2k$								
	Panel thickness, mm								
	50	80	100	120	150	175	200	240	300
Carbon steel	0.02	0.013	0.01	0.009	0.007	0.006	0.005	0.004	0.004
Stainless steel	0.007	0.006	0.003	0.003	0.002	0.002	0.0015	0.001	0.001

**Fig. 5.** Linear thermal conductance coefficient ( $\Psi$  value) for certain details.



$\Psi = 0.12 W/m$



$\Psi = 0.00 W/m$



$\Psi = 0.02 W/m$  for 100 mm  
and 0.008 W/m for 200 mm  
(panel thickness)

## 2 DIMENSIONING

### 2.1 GENERAL

PAROC® Reface™ panels are dimensioned in accordance with EN 14509, as appropriate. The design values for the effect of loads ( $E_d$ ) should be calculated and compared to relevant design values for resistance ( $R_d$ ) taking into account the partial safety coefficients for the material ( $\gamma_m$ ).

#### Ultimate limit state

$$E_d \leq R_d \text{ wherein}$$

$$E_d = \sum \gamma_{fi} \Psi_i S_{ki}$$

$$R_d = R_k / \gamma_m$$

Relevant partial safety coefficients for the load ( $\gamma_f$ ) and consolidation factors ( $\Psi$ ) for loads ( $S_k$ ) must be taken into account in accordance with national standards. Unless otherwise provided in national standards, the partial safety coefficient for the loads should be 1.5. The resistance design values ( $R_d$ ) for the ultimate limit state used in the span graphs and tables include the partial safety coefficients for the materials as follows:

**Table 6.** Material partial safety coefficients ( $\gamma_m$ ) in an ultimate limit state and in a serviceability limit state for panel types AST L, AST S and AST E.

Material partial safety coefficients $\gamma_m$	Ultimate limit state	Serviceability limit state
Top layer yield	1.10	1.00
Wrinkling of the face layer in the span and at an intermediate support/intermediate support	1.26	1.08
Share of the core	1.31	1.08
Compression of the core	1.31	1.08
Failure of the fastener	1.33	1.00

#### Serviceability limit state

$$w_d \leq w$$

The combination of wind and temperature loads in the serviceability limit state are as follows:

- $w_d = 1.0 \times w_{wind}$
- $w_d = 0.75 \times w_{wind} + 0.6 \times w_{temp}$
- $w_d = 0.75 \times 0.6 \times w_{wind} + 1.0 \times w_{temp}$

Unless otherwise provided in national standards, the following deflection limit should be used:

- span / 100 for walls with load and temperature gradient
- span / 150 for walls without a temperature gradient

The dimensioning graphs for Reface panels are based on a temperature gradient throughout the panel of 55 °C. See also section 2.3 Deflection. The dimensioning example is given in section 2.5. The spans specified are only applicable to panels with carbon steel facings.

### 2.1.1 VERTICAL LOADS

PAROC panels will not transfer large loads from e.g. the roof. Despite this, the edge of the panel may be subject to vertical loads from panels or windows above etc. The maximum vertical load the panel edge can be subjected to is 2.5 kN/m.

Vertical loads are usually transferred to the structural frame with penetrating screws. You can find more information on the capacity of the fixings in section 3.

**Fig. 6.** Maximum allowed vertical load for a panel edge with a U-profile.

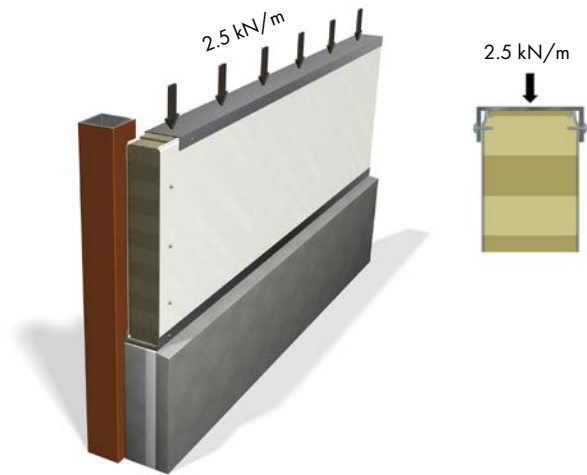

### 2.1.2 SUPPORT WIDTH

The minimum support width values for Reface panels are determined based on span, panel load, structural tolerances and the installation technique used. The recommended practical minimum width of the support is 40 mm for walls. In multi-span structures the minimum width of the intermediate support is 60 mm. The dimensioning must account for frame and panel tolerances.

**Fig. 7.** PAROC Reface panels mounted on to a top hat profile.





When the support width ( $L_s$ ) is known, the resistance design value of the support reaction ( $F_{Rd}$ ) for the ultimate limit state should be calculated as follows:

$$\begin{aligned} \text{at end support} \quad F_{R1,end} &= f_{Cc} \times B \times (L_s + 0.5 \times k \times e) / \gamma_M \\ \text{at intermediate support} \quad F_{R2,intermediate} &= f_{Cc} \times B \times (L_s + k \times e) / \gamma_M \end{aligned}$$

When the design value of the supporting force  $F_d$  is known, the support width  $L_s$  for the ultimate limit state should be calculated as follows:

$$\begin{aligned} \text{at end support} \quad L_{s1,end} &= (\gamma_M \times F_{d1,end} / f_{Cc}) - (0.5 \times k \times e) \\ \text{at intermediate support} \quad L_{s2,intermediate} &= (\gamma_M \times F_{d2,intermediate} / f_{Cc}) - (k \times e) \end{aligned}$$

wherein

- $F_d$  = design support force, kN/m
- $F_R$  = design value of the support resistance of panel, kN
- $f_{Cc}$  = declared value of the compression strength of the core, see table 7
- $L_s$  = support width (m)
- $k$  = distribution parameter = 0.5
- $e$  = distance between centroids of the faces, m  
~ actual thickness of panel – 0.001 m, see table 2
- $B$  = overall width of panel = 1.2 m
- $\gamma_M$  = partial safety factor of stone wool for compression = 1.31

**Table 7.** Compressive strength of PAROC® Reface™ panels.

Compressive strength $f_{cc}$ , kN/m <sup>2</sup>		
Panel type		
AST® L	AST® S	AST® E
42	60	110

## 2.2 EXTERNAL WALLS

### 2.2.1 EXTERNAL WALL LOADS

External walls are dimensioned for wind loads in accordance with Eurocode EN 1991-1-4, taking into account the partial safety coefficients and pressure coefficients in accordance with national regulations as follows:

$$S_d = \gamma_d \times (C_{pe} - C_{pi}) \times q_k$$

wherein

$S_d$  = wind load design value

$\gamma_d$  = partial safety coefficient

$C_{pe}$  = external pressure coefficient

$C_{pi}$  = internal pressure coefficient (= 0.0 when the existing wall structure is bearing the loads due to internal wind pressure)

$q_k$  = characteristic value of the wind load

**Fig. 8.** Base value of wind pressure as a function of building height.

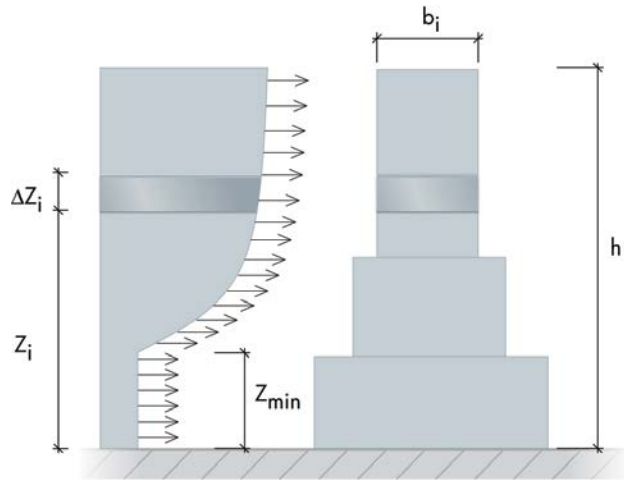

**Fig. 9.** Pressure coefficients.

### 2.2.2 SPANS FOR SINGLE-SPAN EXTERNAL WALLS

- $R_d$  is the panel resistance design value including the partial safety coefficients for materials (but not for the load). These graphs have been calculated for an uniformly distributed load in an ultimate limit state.
- The design value for the load ( $S_d$ ) should be defined according to section 2.2.1.
- See also the dimensioning example in section 2.5.

### 2.2.3 SPANS FOR MULTI-SPAN EXTERNAL WALLS

The intermediate supports of panels with multiple spans are affected simultaneously by the shear force caused by the load and the bending moment. The temperature gradient between the exterior and interior surface of the panel increases the bending moment at intermediate supports. This is why the spans are limited. Support widths and the number of fixings should be calculated on a case-by-case basis.

For more information, contact Paroc Panel System.

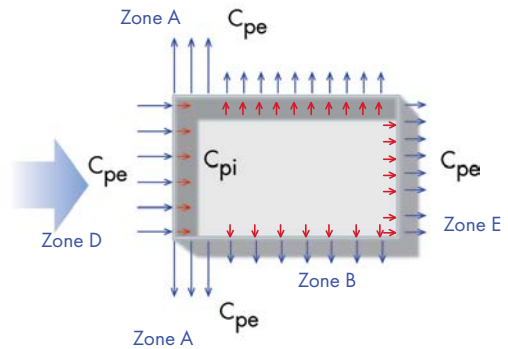
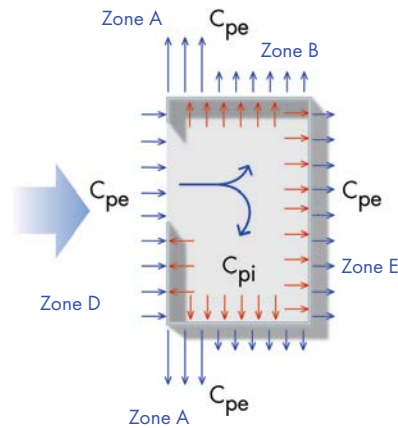

Fig. 10a. Spans for single-span external walls with temperature gradient; panel thickness 50 mm

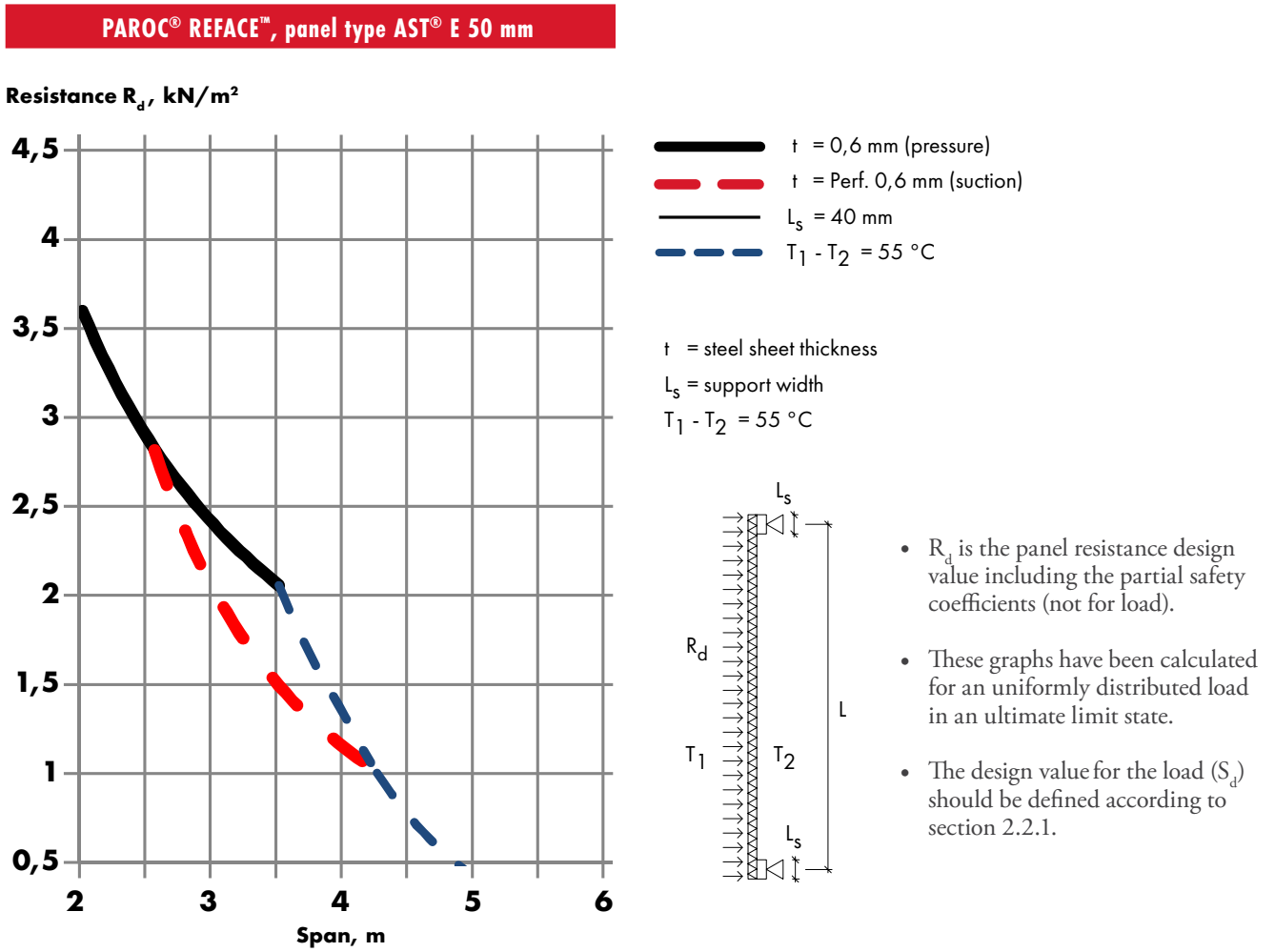
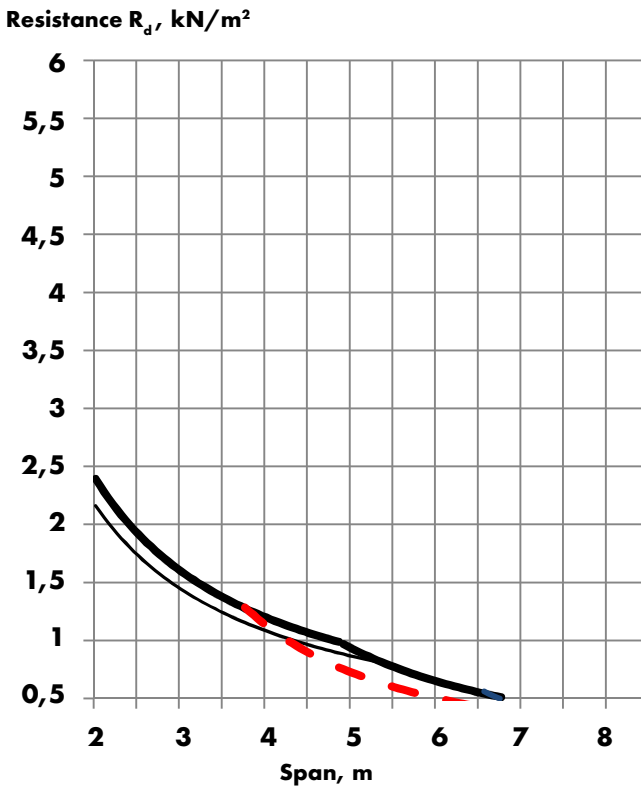
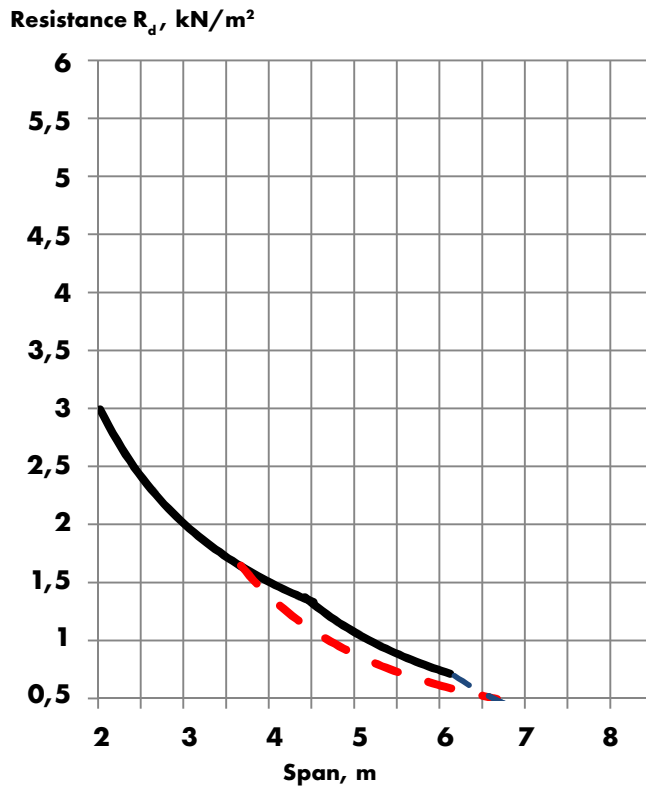

Fig. 10b. Spans for single-span external walls with temperature gradient; panel thickness 80 mm

**PAROC® REFACE™, panel type AST® L 80 mm**



**PAROC® REFACE™, panel type AST® S 80 mm**



**PAROC® REFACE™, panel type AST® E 80 mm**

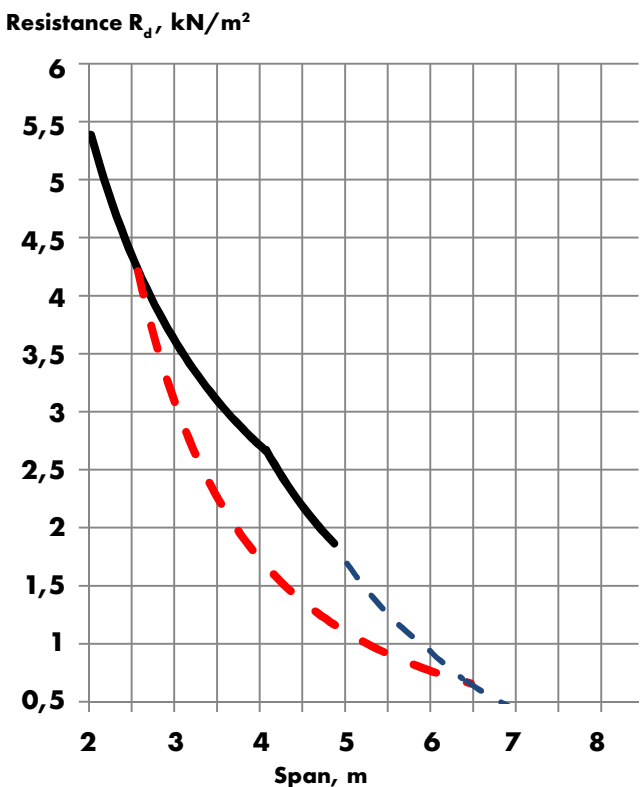

$t$  = steel sheet thickness  
 $L_s$  = support width  
 $T_1 - T_2 = 55 \text{ }^\circ\text{C}$

- $t = 0,6 \text{ mm}$  (pressure)
- $t = \text{Perf. } 0,6 \text{ mm}$  (suction)
- $L_s = 40 \text{ mm}$
- $T_1 - T_2 = 55 \text{ }^\circ\text{C}$

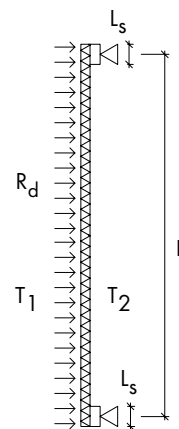

- $R_d$  is the panel resistance design value including the partial safety coefficients (not for load).
- These graphs have been calculated for an uniformly distributed load in an ultimate limit state.
- The design value for the load ( $S_d$ ) should be defined according to section 2.2.1.

Fig. 10c. Spans for single-span external walls with temperature gradient; panel thickness 100 mm

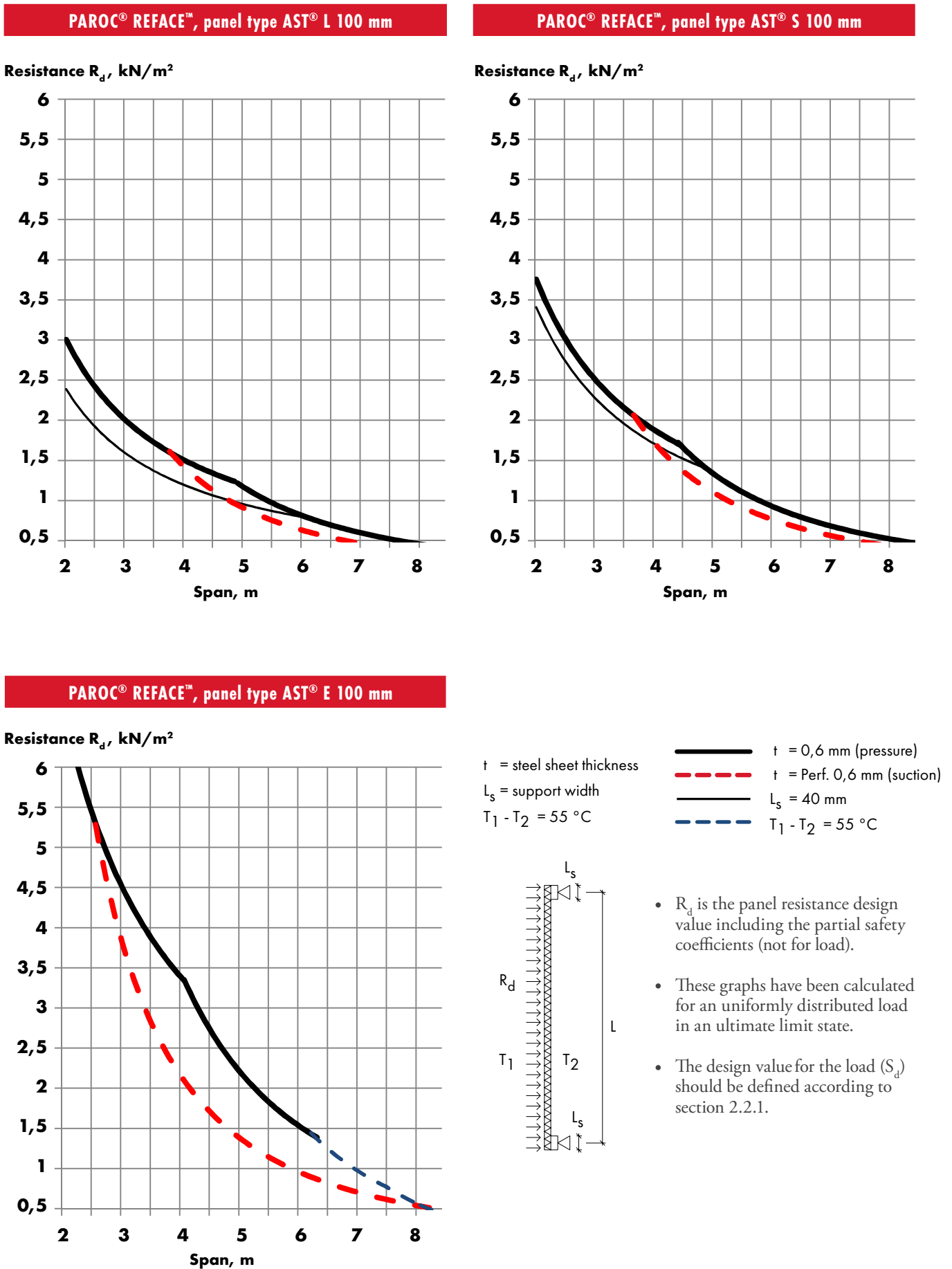
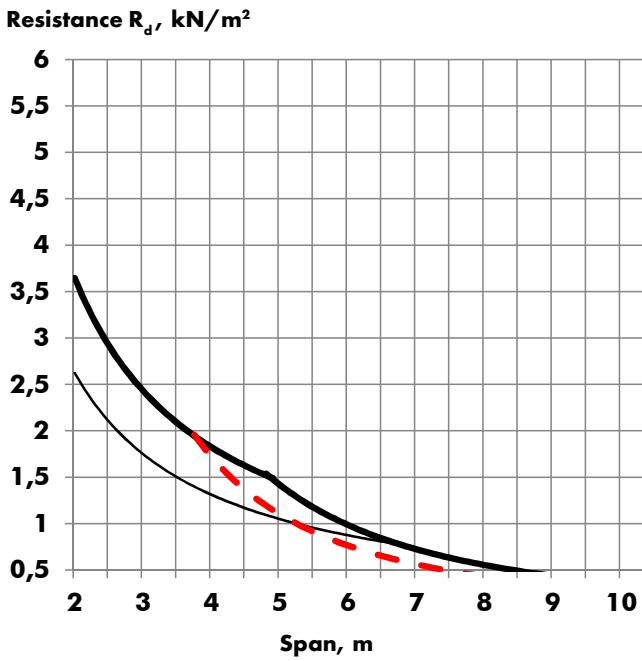
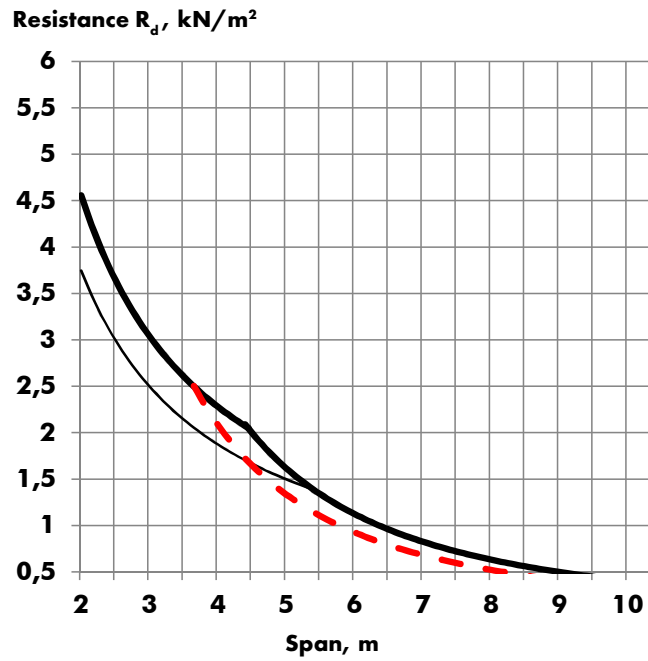

Fig. 10d. Spans for single-span external walls with temperature gradient; panel thickness 120 mm

**PAROC® REFACE™, panel type AST® L 120 mm**



**PAROC® REFACE™, panel type AST® S 120 mm**



**PAROC® REFACE™, panel type AST® E 120 mm**

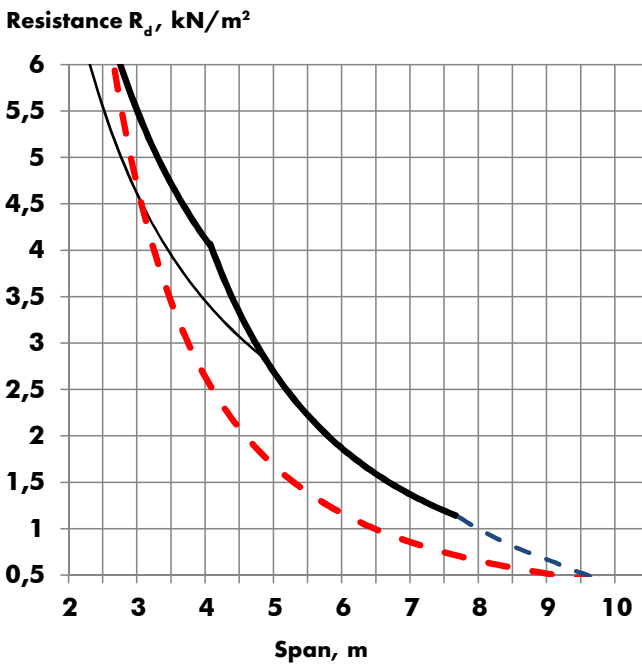

$t$  = steel sheet thickness  
 $L_s$  = support width  
 $T_1 - T_2 = 55\text{ °C}$

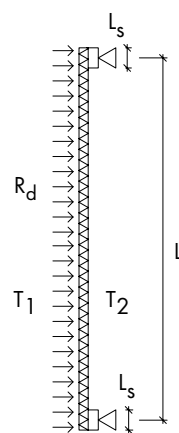

- $R_d$  is the panel resistance design value including the partial safety coefficients (not for load).
- These graphs have been calculated for an uniformly distributed load in an ultimate limit state.
- The design value for the load ( $S_d$ ) should be defined according to section 2.2.1.

Fig. 10e. Spans for single-span external walls with temperature gradient; panel thickness 150 mm

**PAROC® REFACE™, panel type AST® L 150 mm**

Resistance  $R_d$ , kN/m<sup>2</sup>

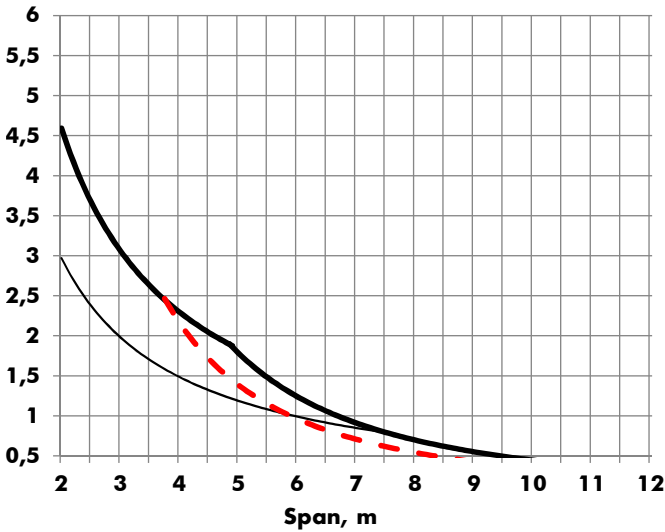

**PAROC® REFACE™, panel type AST® S 150 mm**

Resistance  $R_d$ , kN/m<sup>2</sup>

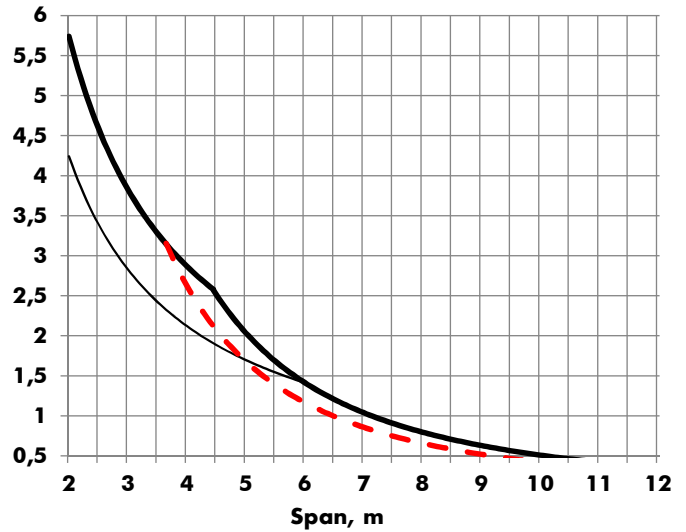

**PAROC® REFACE™, panel type AST® E 150 mm**

Resistance  $R_d$ , kN/m<sup>2</sup>

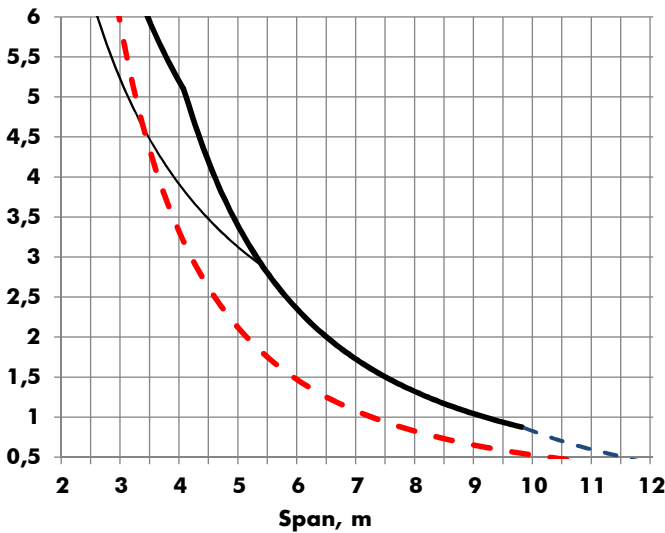

- $t$  = steel sheet thickness
  - $L_s$  = support width
  - $T_1 - T_2 = 55$  °C
- $t = 0,6$  mm (pressure)
  - $t = \text{Perf. } 0,6$  mm (suction)
  - $L_s = 40$  mm
  - $T_1 - T_2 = 55$  °C

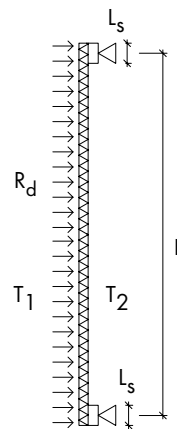

- $R_d$  is the panel resistance design value including the partial safety coefficients (not for load).
- These graphs have been calculated for an uniformly distributed load in an ultimate limit state.
- The design value for the load ( $S_d$ ) should be defined according to section 2.2.1.

Fig. 10f. Spans for single-span external walls with temperature gradient; panel thickness 175 mm

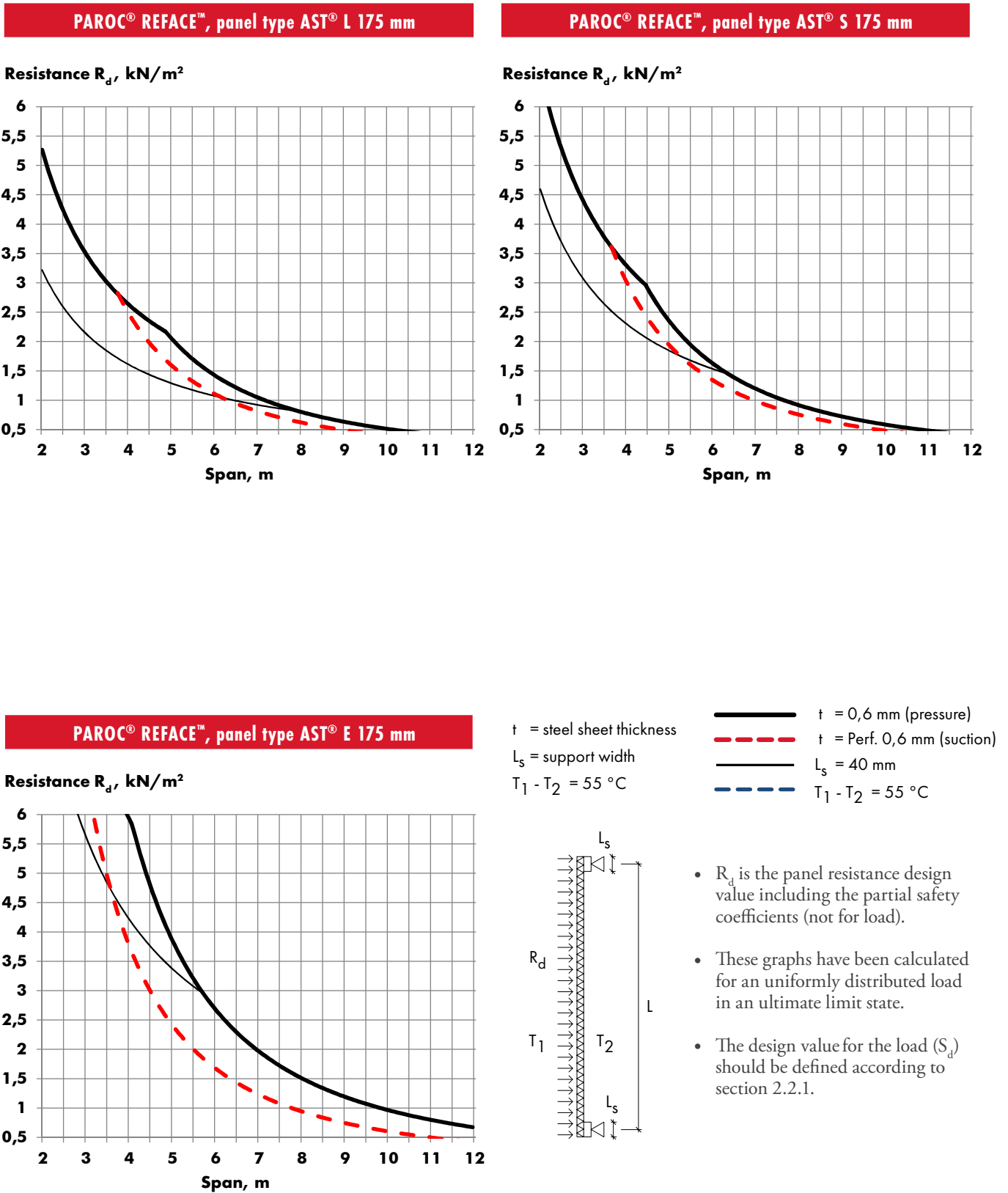



Fig. 10g. Spans for single-span external walls with temperature gradient; panel thickness 200 mm

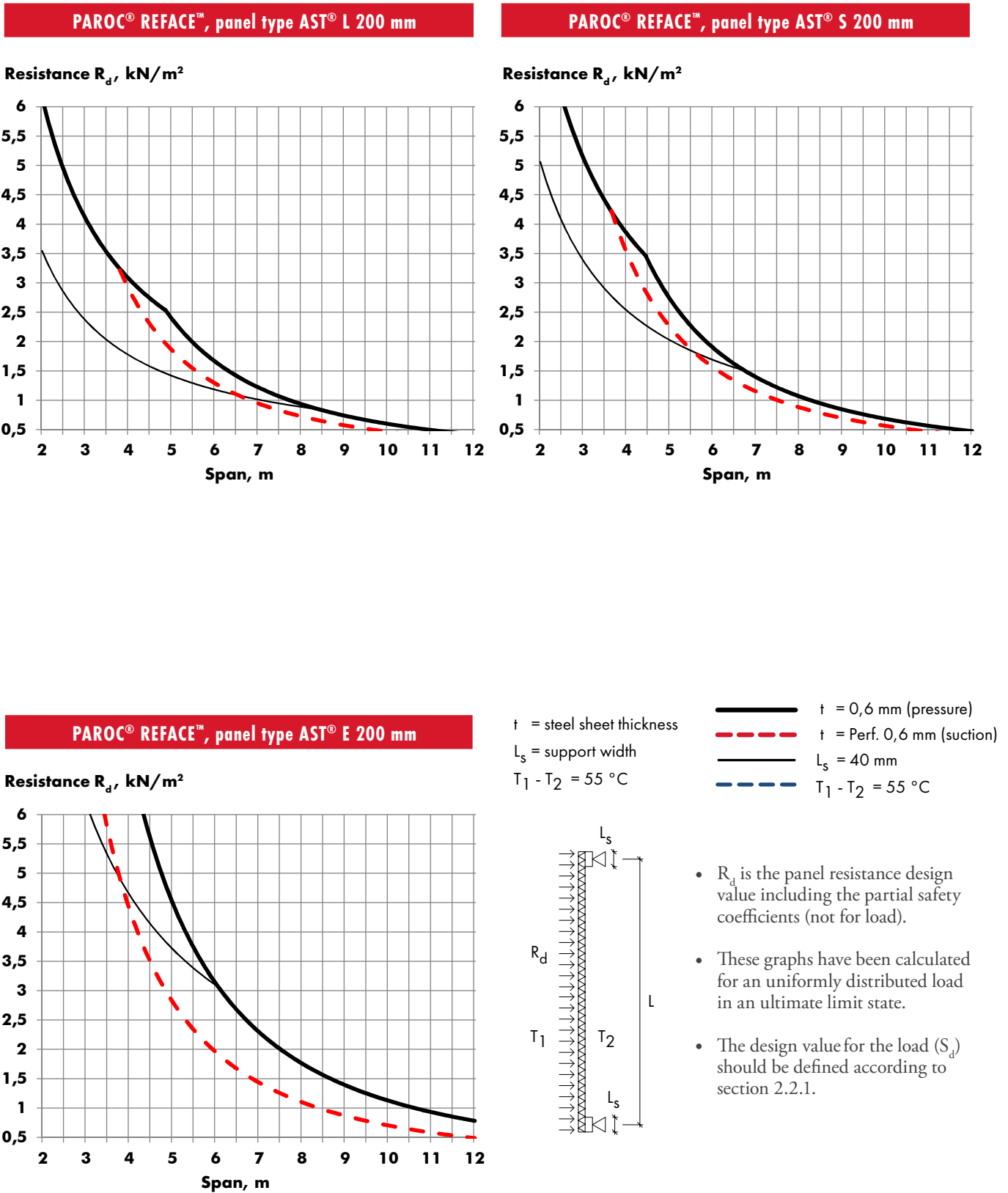
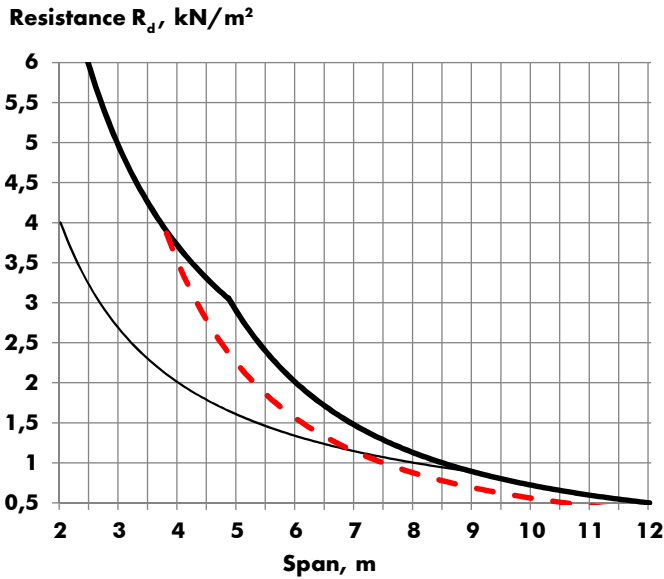
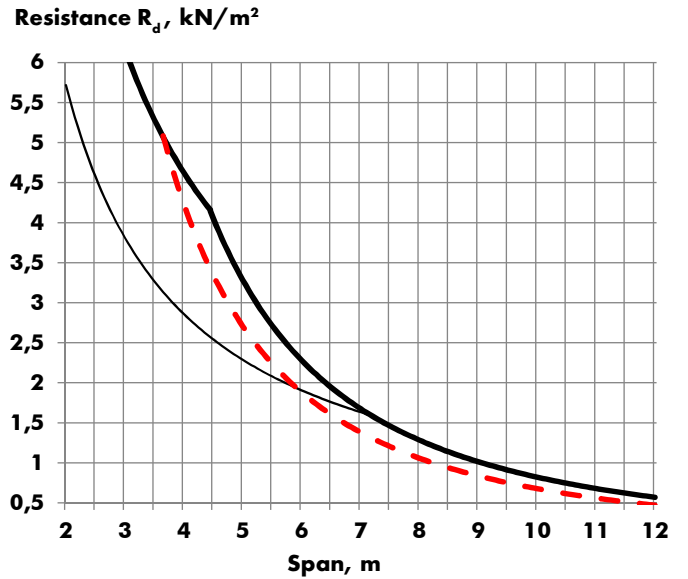

Fig. 10b. Spans for single-span external walls with temperature gradient; panel thickness 240 mm

**PAROC® REFACE™, panel type AST® L 240 mm**



**PAROC® REFACE™, panel type AST® S 240 mm**



**PAROC® REFACE™, panel type AST® E 240 mm**

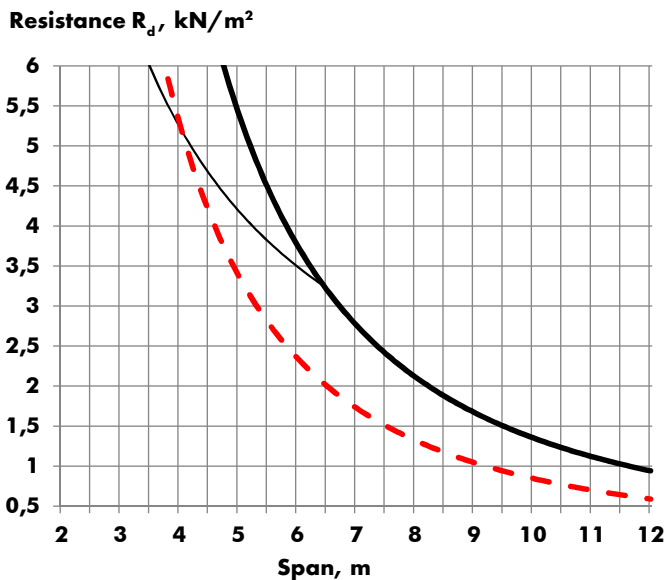

$t$  = steel sheet thickness

$L_s$  = support width

$T_1 - T_2 = 55\text{ °C}$

—  $t = 0,6\text{ mm}$  (pressure)

- - -  $t = \text{Perf. } 0,6\text{ mm}$  (suction)

—  $L_s = 40\text{ mm}$

- - -  $T_1 - T_2 = 55\text{ °C}$

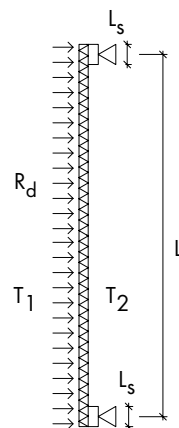

- $R_d$  is the panel resistance design value including the partial safety coefficients (not for load).
- These graphs have been calculated for an uniformly distributed load in an ultimate limit state.
- The design value for the load ( $S_d$ ) should be defined according to section 2.2.1.

Fig. 10i. Spans for single-span external walls with temperature gradient; panel thickness 300 mm

**PAROC® REFACE™, panel type AST® L 300 mm**

Resistance  $R_d$ , kN/m<sup>2</sup>

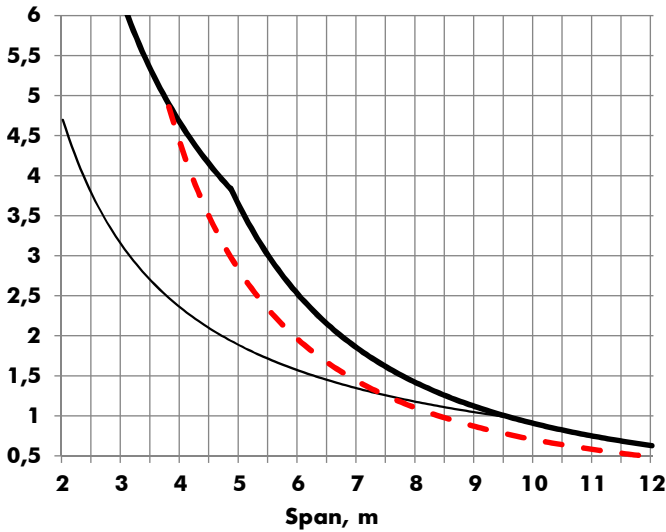

**PAROC® REFACE™, panel type AST® S 300 mm**

Resistance  $R_d$ , kN/m<sup>2</sup>

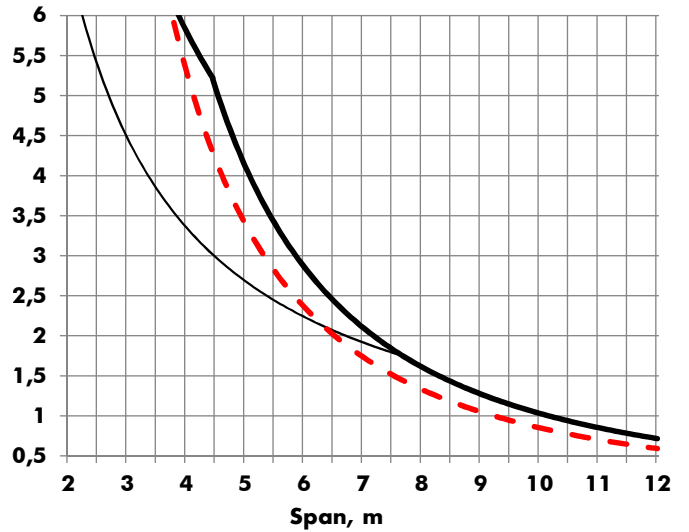

**PAROC® REFACE™, panel type AST® E 300 mm**

Resistance  $R_d$ , kN/m<sup>2</sup>

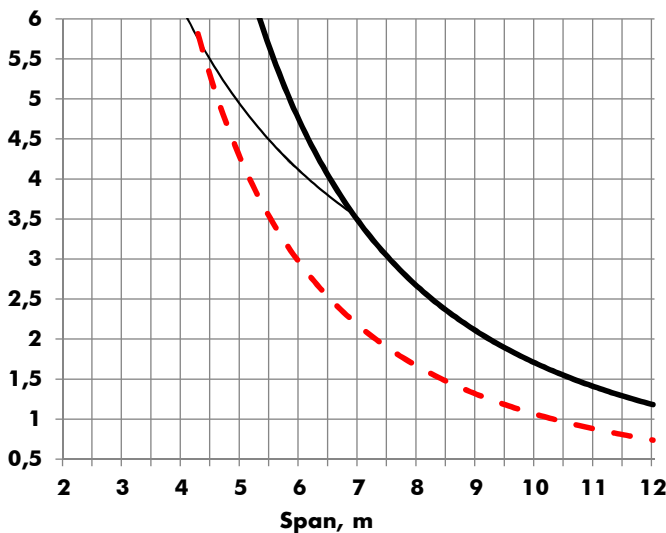

$t$  = steel sheet thickness  
 $L_s$  = support width  
 $T_1 - T_2 = 55\text{ °C}$

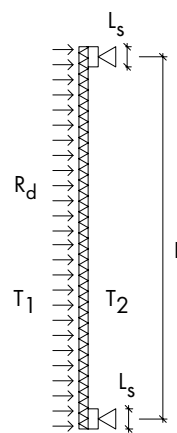

- $R_d$  is the panel resistance design value including the partial safety coefficients (not for load).
- These graphs have been calculated for an uniformly distributed load in an ultimate limit state.
- The design value for the load ( $S_d$ ) should be defined according to section 2.2.1.

### 2.3 DEFLECTION

The panels deflect due to loads (wind pressure and suction) and due to the temperature gradient between the interior and exterior surfaces of the panel. This deflection must be taken into account when designing details.

The panel will bend towards the warmer environment. Unless other values are available, the following European sandwich panel guidance values can be used as a reference for surface temperatures:

- **Interior surface**  
+20 °C in winter  
+25 °C in summer
- **Exterior surface**  
Minimum temperature in winter  
-20 °C in Central Europe  
-30 °C in Northern Europe  
In the summer, the maximum temperature of the panel's exterior surface will depend on the colour and the reflectivity of the exterior surface. See Table 8.

**Table 8.** Colour group, absorption coefficients and exterior surface temperatures of the exterior surface of the panel in summer.

Colour group	Colours	Absorption coefficient	Exterior surface temperature
I	RR20, R106, R108, R143, R807	10–25 %	+55 °C
II	RR21, RR24, RR34, RR40	25–60 %	+65 °C
III	R502, RR23, RR35, RR29, RR41, stainless steel	60–92 %	+80 °C

**Table 9.** Deflection caused by temperature differences. The deflection rate for other temperature differences can be calculated by multiplying the table values proportionally according to the temperature differences.

Span, m	$\Delta T, ^\circ C$	Deflection, mm							
		Panel thickness, mm							
		80	100	120	150	175	200	240	300
3.0	40	7	6	5	4	3	3	2	2
	55	9	8	6	5	4	4	3	2
4.5	40	15	12	10	8	7	6	5	4
	55	21	17	14	11	10	8	7	6
6.0	40	27	22	18	14	13	11	9	7
	55	38	30	25	20	17	15	12	10
7.5	40	42	34	28	22	20	17	14	11
	55	59	47	39	31	27	23	19	15
9.0	40	61	49	40	32	28	24	20	16
	55	85	68	57	44	39	33	28	22

**Table 10.** Deflection due to uniform load.

Span, m	Load, kN/m <sup>2</sup>	Deflection, mm							
		Panel thickness, mm							
		80	100	120	150	175	200	240	300
3.0	0.1	1	1	1	1	1	1	1	0
	0.3	2	2	1	1	1	1	1	0
	0.6	4	3	2	2	1	1	1	1
	1.0	7	5	4	3	2	2	2	1
4.5	0.1	2	2	1	1	1	1	1	0
	0.3	7	5	4	3	2	2	1	1
	0.6	15	10	8	5	4	3	3	2
	1.0	–	17	13	9	7	6	4	3
6.0	0.1	7	5	3	2	2	1	1	1
	0.3	20	14	10	7	5	4	3	2
	0.6	38	25	20	13	11	8	6	4
	1.0	–	–	33	22	18	14	10	7
7.5	0.1	15	10	7	5	4	3	2	1
	0.3	46	30	21	14	11	9	6	4
	0.6	–	–	43	28	22	17	13	9
	1.0	–	–	–	47	37	29	21	15
9.0	0.1	30	20	14	9	7	5	4	3
	0.3	–	57	42	27	21	16	12	8
	0.6	–	–	–	55	43	32	23	16
	1.0	–	–	–	–	71	54	39	26

Generally, deflection caused by loads is significant in serviceability limit state. In this case, load refers to a wind load that occurs a few times a year, rather than the loads used for the dimensioning of the panels (for most standards, this is equal to a wind load likely to occur once every 50 years)

**Table 11.** Wind load as a function of wind speed.

Type	Wind speed and wind load	
	Speed, m/s	Load, kN/m <sup>2</sup>
Weak wind	3–5	0.01
Brisk wind	8–11	0.05
Strong wind	14–17	0.15
Gale	24–28	0.42
Hurricane	33	0.70

## 2.4 OPENINGS ON DIMENSIONING

Openings for doors and windows as well as any penetrations in the panels may decrease the strength of the panel. This must be taken into account when dimensioning PAROC panels. Panels with openings should be dimensioned to withstand any loads despite the openings. If this is not possible, any loads on panels with openings must be transferred either to adjacent panels or to the building frame by using auxillary structures.

For large openings, such as doors, the wind load should be transferred to the frame using steel profiles.

The panel openings for penetrations are usually so small that the decrease in panel strength will not necessitate any special measures. If necessary, a higher-strength panel type may be used.

**Fig. 11.** Allowed load ( $q$ ) for panels with openings. The allowed load for a panel with openings ( $q_{all}$ ) can be identified from dimensioning graphs for the relevant span and with the largest support width.

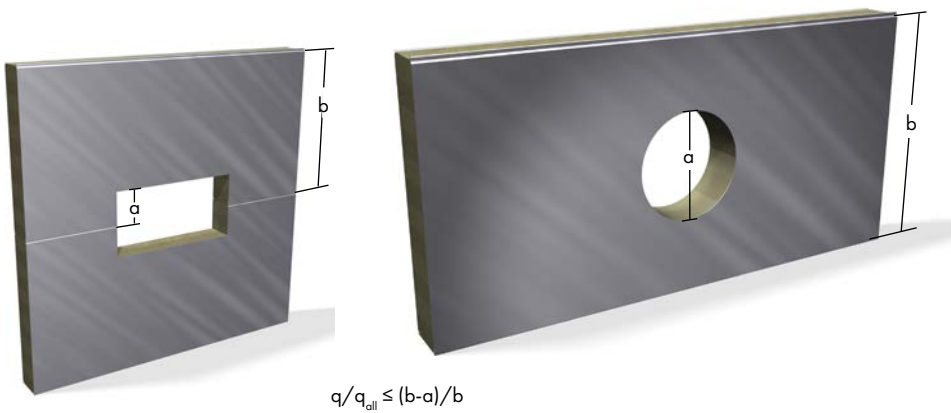

However, if the proportion of openings is more than the ratio  $q / q_{all}$ , the loads may be transferred to adjacent panels in accordance with Fig. 14. If this is not possible, the loads should be transferred to the structural frame by using auxillary structures. See also the dimensioning example in section 2.5.

Fig. 12. Transfer coefficients for loads.

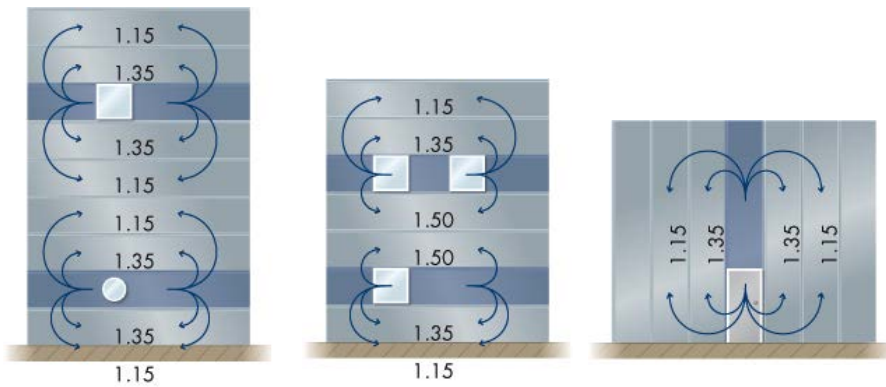

## 2.5 DIMENSIONING EXAMPLE

### External wall, horizontal installation

Frame	Span L = 3.6 m
Panel type	PAROC® Reface™ AST® L
Panel thickness	80 mm
Facings	Exterior – 0.6 mm, dark colour (colour group III, see Table 8) Interior – 0.6 mm, perforated
Wind load	$q_k = 1.0 \text{ kN/m}^2$ , characteristic value
Load safety coefficient	$\gamma_d = 1.5$
Pressure coefficients	$c_p = 0.8$ (external pressure) + 0.0 (internal suction) = 0.8 (zone D) $c_p = -0.8$ (external suction) + 0.0 (internal pressure) = -0.8 (zone B) $c_p = -1.2$ (external suction) + 0.0 (internal pressure) = -1.2 (zone A)

Design value for wind load

$$W_{d,D} = 1.5 \times (0.8 \times 1.0) \text{ kN/m}^2 = 1.2 \text{ kN/m}^2 \text{ (zone D)}$$

Design value for wind suction

$$W_{d,B} = 1.5 \times (-0.8 \times 1.0) \text{ kN/m}^2 = -1.2 \text{ kN/m}^2 \text{ (zone B)}$$

$$W_{d,A} = 1.5 \times (-1.2 \times 1.0) \text{ kN/m}^2 = -1.8 \text{ kN/m}^2 \text{ (zone A)}$$

The design value for the resistance of the chosen panel type can be identified using the graph in Fig. 10b.

In the case of wind pressure (zone D), the resistance is determined by compression:

$$R_d = 1.2 \text{ kN/m}^2 \geq W_{d,D} = 1.2 \text{ kN/m}^2$$

In the case of wind suction (zone B), the resistance is determined by the share:

$$R_d = 1.3 \text{ kN/m}^2 \geq W_{d,B} = |-1.20| \text{ kN/m}^2$$

In the case of wind suction (zone A), the resistance is determined by the share:

$$R_d = 1.3 \text{ kN/m}^2 \leq W_{d,A} = |-1.80| \text{ kN/m}^2, \text{ so the resistance is exceeded}$$

The panel type AST® S is chosen, share

$$R_d = 1.7 \text{ kN/m}^2 \leq W_{d,A} = |-1.80| \text{ kN/m}^2, \text{ so the resistance is exceeded}$$

The panel type AST® E is chosen, local buckling of interior sheet

$$R_d = 2.1 \text{ kN/m}^2 \geq W_{d,A} = |-1.80| \text{ kN/m}^2, \text{ so the resistance is adequate}$$

For wall sections without openings, the following panel types should be chosen:

AST® L (zones: B – wind suction, D – wind pressure)

AST® E (zone: A – wind suction in a corner)

### Dimensioning of the opening

The height of the window fitted into the panel is the same as the width of the panel – 1,200 mm.  
In accordance with Fig. 11, the load transfer coefficient for the adjacent panels is 1.35, and 1.15 for any subsequent panels.

$$\begin{aligned} \text{Design value for wind pressure } W_{d,D} &= 1.35 \times 1.5 \times (0.8 \times 1.0) \text{ kN/m}^2 = 1.62 \text{ kN/m}^2 \text{ (zone D)} \\ \text{Design value for wind suction } W_{d,B} &= 1.35 \times 1.5 \times (-0.8 \times 1.0) \text{ kN/m}^2 = |-1.62| \text{ kN/m}^2 \text{ (zone B)} \end{aligned}$$

In both cases, the design value exceeds the resistance of the AST® L panel, so this panel type must be replaced with the panel type AST® S, so that  $R_d = 1.7 \text{ kN/m}^2$  (share) is large enough.

A corresponding window opening in zone A subjects the adjacent panel to the following loads:

$$\begin{aligned} \text{Design value for wind pressure } W_{d,A} &= 1.35 \times 1.5 \times (0.8 \times 1.0) \text{ kN/m}^2 = 1.62 \text{ kN/m}^2 \text{ (zone A)} \\ \text{Design value for wind suction } W_{d,A} &= 1.35 \times 1.5 \times (-1.2 \times 1.0) \text{ kN/m}^2 = |-2.43| \text{ kN/m}^2 \text{ (zone A)} \end{aligned}$$

The suction loads exceed the resistance of the AST® S and AST® E panels  $R_d = 2.1 \text{ kN/m}^2$  (local buckling of interior sheet).  
The window must therefore be supported by the existing wall structure, rather than adjacent panels.

### Support widths

The panel resistance design value when utilising the minimum support width (40 mm) can be identified using the graph in Fig. 10b.  
In the case of wind pressure (zone D), the resistance is determined for the minimum support width:

$$R_{d,\text{supp}} = 1.2 \text{ kN/m}^2 > W_{d,D} = 1.2 \text{ kN/m}^2$$

The load that panels next to the window are subjected to in the case of wind pressure, load transfer coefficient 1.35:

$$\begin{aligned} \text{Design value for wind pressure } W_{d,D} &= 1.35 \times 1.5 \times (0.8 \times 1.0) = 1.62 \text{ kN/m}^2 \text{ (zone D) is less than} \\ R_{d,\text{supp}} &= 1.7 \text{ kN/m}^2 \text{ (AST® S).} \end{aligned}$$

### Mounting with penetrating panel fixings

The number of fixings is determined in accordance with section 3.2.1. The allowed load for penetrating fixings with 19 mm washers is  $F_{\text{all}} = 0.8 \text{ kN}$ , when AST L and 1.0 kN, when AST S or E (ks. Table 12).

The number of fixings per panel end is calculated as follows:

$$\begin{aligned} \text{In the case of wind suction (zone B) } N &= 0.5 \times 3.6 \text{ m} \times 1.2 \text{ m} \times (-0.8 \times 1.0 \text{ kN/m}^2) / 0.8 \text{ kN} \\ &= 2.16 \Rightarrow 3 \text{ fixings per panel end} \end{aligned}$$

$$\begin{aligned} \text{In the case of wind suction (zone A) } N &= 0.5 \times 3.6 \text{ m} \times 1.2 \text{ m} \times (-1.2 \times 1.0 \text{ kN/m}^2) / 1.0 \text{ kN} \\ &= 2.6 \Rightarrow 3 \text{ fixings per panel end} \end{aligned}$$

The load that panels next to the window are subjected to in the case of wind pressure, load transfer coefficient 1.35:

$$\begin{aligned} N &= 0.5 \times 3.6 \text{ m} \times 1.2 \text{ m} \times 1.35 \times (-0.8 \times 1.0 \text{ kN/m}^2) / 1.0 \text{ kN} \\ &= 2.3 \Rightarrow 3 \text{ fixings per panel end} \end{aligned}$$

### Deflection

Deflections can be obtained from the tables 9 and 10.

The load resulting from a uniform load is approximately 10 mm when the wind suction is (zone B)

$$w_k = (-0.8 - 0.0) \times 1.0 \text{ kN/m}^2 = -0.8 \text{ kN/m}^2.$$

The deflection due to the temperature difference is approximately 15 mm when the temperature gradient is  $(+80 \text{ }^\circ\text{C} - +25 \text{ }^\circ\text{C}) = +55 \text{ }^\circ\text{C}$  in summer.

Combined loads:

$$w_1 = 1.0 \times 0.75 \times 100 \% \times 10 \text{ mm} + 1.0 \times 60 \% \times 15 \text{ mm} = 16.5 \text{ mm, which corresponds to the deflection } L/218$$

$$w_2 = 1.0 \times 0.75 \times 60 \% \times 10 \text{ mm} + 1.0 \times 100 \% \times 15 \text{ mm} = 19.5 \text{ mm, which corresponds to the deflection } L/185$$

$$w_3 = 1.0 \times 100 \% \times 10 \text{ mm} = 10 \text{ mm, which corresponds to the deflection } L/360$$

The deflection resulting from other combined loads should be calculated in a similar way.

This deflection must be taken into account when designing details.



## 3 FASTENINGS

### 3.1 PANEL FIXINGS

When selecting panel fixings, any loads and the aggressiveness of both the inside and the outside environment should be taken into account. Any panel fixings remaining visible or subjected to high levels of humidity should be stainless steel ones. In practice, defining the exact environmental category is challenging, which is why we recommend the use of stainless steel fixings for all installations. The profiles used for fixing the panels or as support are usually made of 1 - 4 mm thick galvanized steel and they are to be dimensioned by the designer.

### 3.2 FASTENING WALL PANELS

PAROC panels can be installed either horizontally or vertically. The panels should usually be installed with penetrating panel fixings or with L-profiles. When installing, make sure that the panels are fixed through both facings. When dimensioning the fixings for multi-span panels, please contact Paroc Panel System.

#### 3.2.1 MOUNTING WITH PENETRATING PANEL FIXINGS

This mounting method is suitable for the vertical and horizontal installation of external walls. The fixing type should be chosen based on the frame material.

*Fig. 13. Installing PAROC panels with penetrating panel fixings.*

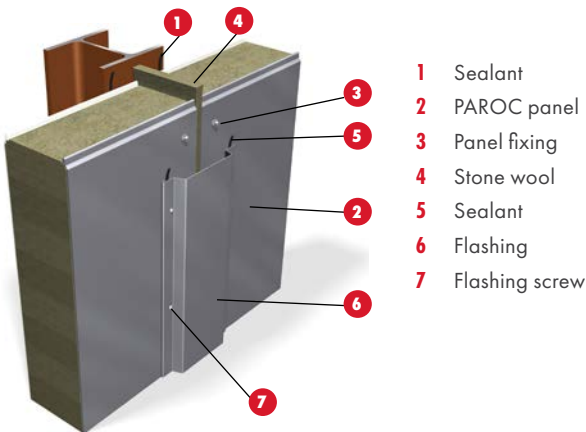

- 1 Sealant
- 2 PAROC panel
- 3 Panel fixing
- 4 Stone wool
- 5 Sealant
- 6 Flashing
- 7 Flashing screw

The number of panel fixings should be determined on the basis of loads (suction), panel length, span, panel weight and any loads due to windows or other elements. Pressure coefficients must be accounted for, especially in corners. The minimum number of fixings for each panel end is 2. The minimum distance from the end of the panel is 20 mm. The number of fixings for each panel end should be calculated as follows:

$$N = 0.5 \times L \times b \times C_p \times q_w / F_{all}$$

wherein

- N = number of fixings for panel end
- L = panel length (m)
- b = panel width (m)
- $C_p$  = pressure coefficient for suction  
(external suction + internal pressure, see Fig. 9)
- $q_w$  = characteristic wind load kN/m<sup>2</sup>
- $F_{all}$  = allowed load for panel fixings from Table 12.

The number of fixings for an acceptable tensile strength in an ultimate limit state should be calculated according to following formula:

$$F_d \leq n \times N_{R,d}$$

$$\gamma_f \times F_k \leq n \times N_{R,k} / \gamma_m$$

$$F_k \leq n \times N_{R,k} (\gamma_m \times \gamma_f) = n \times F_{t,all}$$

wherein

- $F_d$  = effect on panel end, design value  
(incl. partial safety coefficient)
- n = number of fixings per panel end
- $N_{R,d}$  = tensile strength of fixing, design value  
(incl. partial safety coefficient)
- $N_{R,k}$  = characteristic tensile strength of fixing
- $F_k$  = characteristic live load for panel end
- $\gamma_f$  = partial safety coefficient for load = 1.5
- $\gamma_m$  = partial safety coefficient for material = 1.33
- $F_{all}$  = allowed load per fixing (incl. partial safety coefficient)

Table 12. Allowed loads for penetrating panel fasteners.

Panel fasteners Ø 5.5/6.3 mm	Allowed load $F_{all}$ , kN								
	Tensile strength						Share		
	AST® L			AST® S, AST® E			All panel types		
	$N_{R,k}$	$N_{R,d}$	$F_{t,perm}$	$N_{R,k}$	$N_{R,d}$	$F_{t,perm}$	$V_{R,k}$	$V_{R,d}$	$F_{v,perm}$
Washer Ø 19 mm	1.60	1.20	0.80	2.00	1.50	1.00	2.00	1.50	1.00
Washer Ø 29 mm	1.60	1.20	0.80	2.15	1.62	1.10	2.00	1.50	1.00
Embedded washer Ø 40 mm	1.60	1.20	0.80	2.15	1.62	1.10	2.00	1.50	1.00

The above values given by the manufacturer are only applicable when the corresponding values for the mounting plate are equivalent to them or greater.

**3.3 FIXING OF FLASHINGS**

Flashings should be installed using stainless steel screws or rivets in accordance with the following instructions:

- Flashings should be installed with screws or rivets (c 300 mm)
- Avoid fixing screws to flashing joints, as this will ensure the elasticity of the joints
- One expansion joint will be needed for each 12-metre section of steel flashings and for each 6-metre section of aluminium flashings
- External wall flashing edges must be bent inwards
- For internal walls, flashings with slightly bent edges may be used
- In horizontally-installed walls, the flashing joints should be placed on top of panel joints, when possible.

**3.4 SUSPENSIONS**

**3.4.1 FORCES**

Loads are usually caused by the weight of the structures as well as wind pressure and suction. Variable loads include snow and ice that may build up on the structures. In addition, it is important to consider any movement in the structures due to changes in temperature and moisture and the effect of this on fixings. If a dynamic load from suspension is present, penetrating panel fixings must be used. Suspension loads must also be taken into account when dimensioning for panel fixing screws.

The maximum allowed weight of additional cladding is 45 kg/m<sup>2</sup>. The cladding should be installed to the sections with a maximum allowed distance of 600 mm when installed along the panel or 1,200 mm in a crosswise direction.

Suspensions result in a share forces along the panel facing ( $F_v$ ) and/or a tensile force ( $F_t$ ) or a compression ( $F_p$ ) down towards the panel facing.

**3.4.2 ALLOWED LOADS**

The suspensions require that the panel facing sheets do not detach (delaminate) from the core material. Therefore, the basic requirement for the specific adhesive strength in tension is greater than 100 kPa. The specific adhesive strength in tension of all PAROC® REFACE™ panels (panel types AST® L, AST® S and AST® E) exceeds this limit.

It is important to use rivets and screws that are appropriate for fixing structures on to thin sheet steel. The allowed loads for Bulb-tite and Peel rivets and for lapped self-tapping screws for mounting steel sheets are listed in the following table

Fig. 14. Suspension load.

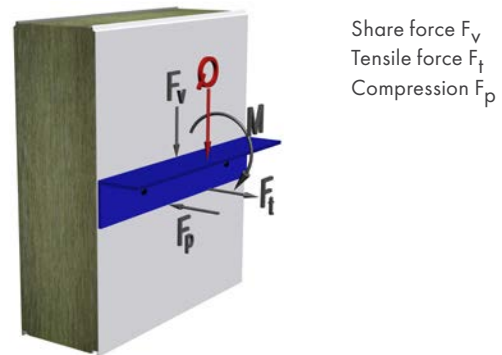

Share force  $F_v$   
Tensile force  $F_t$   
Compression  $F_p$

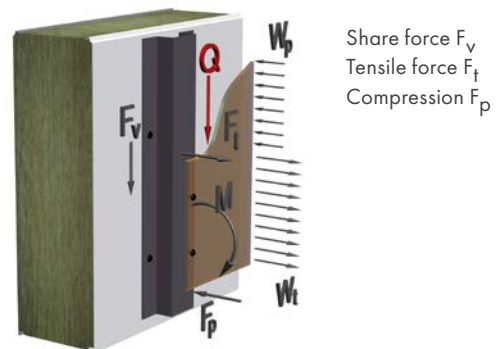

Share force  $F_v$   
Tensile force  $F_t$   
Compression  $F_p$

**Table 13.** Allowed loads for surface fixings when the minimum distance between fixing screws is 120 mm. These values are applicable to all panel types and to panel facing thicknesses 0.5, 0.6 and 0.7 mm. In some countries, the values may differ from those listed here.

Fixing	Allowed load $F_{all}$ , kN		
	Share $F_{v,all}$	Tensile, wall $F_{t,all}$	
		AST®	AST® S, AST® E
Over lapping steel sheet screw Ø 4.8–6.3 mm	500	200	250
Bulb-tite/Peel rivet	500	300	400

The following limits must be taken into account when dimensioning suspensions:

### 1. Shear force resulting from suspension

$$F_v \leq n \times F_{v,all}$$

wherein

- $F_v$  = shear force resulting from suspension – N (specific)
- $n$  = number of fixings
- $F_{v,all}$  = shear force allowed for one fixing – N (from Table 13)

The maximum allowed shear force for a support profile is 2.5 kN/m, the Bulb-tite/Peel rivets being distributed c/c 200 mm apart.

### 2. Tensile force resulting from suspension

$$F_t \leq n \times F_{t,all}$$

wherein

- $F_t$  = tensile force resulting from suspension – N (specific)
- $n$  = number of fixings
- $F_{t,all}$  = tensile force allowed for one fixing – N (from Table 13)

The maximum allowed tensile force for a support section is 2.0 kN/m, the screws being distributed c/c 120 mm apart and the Bulb-tite/Peel rivets being distributed c/c 200 mm apart.

### 3. Compression resulting from suspension

$$F_p \leq F_{p,all} = f_{Cc,k} \times (A_s + B \times e) / (\gamma_M \times \gamma_F)$$

wherein

- $F_p$  = compression resulting from suspension N (specific)
- $F_{p,all}$  = allowed compression on facing sheet – N
- $f_{Cc,k}$  = specific compression resistance of wool core, N/mm<sup>2</sup> (from Table 14)
- $A_s$  = stiff support area of profile, mm<sup>2</sup>
- $B$  = perimeter of support area, mm
- $e$  = determined dimension – mm, when the support width  $a \geq 60$  mm. When the width  $a < 60$  mm, the dimension must be multiplied by the coefficient  $k_e = 1 - (60 - a) / 60$
- $\gamma_M$  = compression material safety coefficient, [1.33]
- $\gamma_F$  = safety coefficient for load, [1.5]

**Table 14.** Characteristics compression strength of wool  $f_{C_c,k}$  and e-dimensions for different panel types.

Panel type	AST® L	AST® S	AST® E
$f_{C_c,k}$	0.042 N/mm <sup>2</sup>	0.060 N/mm <sup>2</sup>	0.110 N/mm <sup>2</sup>
e-dimension	50 mm	40 mm	20 mm

**4. If tensile and shear force are active simultaneously (EN 1993-1-3)**

$$(F_t / F_{t,all}) + (F_v / F_{v,all}) \leq 1$$

**5. If compression and shear force are active simultaneously**

$$(F_p / F_{p,all}) + (F_v / F_{v,all}) \leq 1$$

**6. If one part of the structure is affected by both a tensile and a compression force**  
(e.g. wind suction and pressure)

$$(F_t / F_{t,all})^2 + (F_p / F_{p,all})^2 \leq 1$$

When a profile that is being mounted, or a support plate which has been both glued and mechanically installed to the facing sheet, is affected by both a tensile and a compression force, the following limits for tension and compression must be checked:

$$\text{Tension } F_{t,all} = f_{C_c,k} \times (A_s + B \times e) / (k \times \gamma_M \times \gamma_F)$$

wherein

- $F_{t,all}$  = allowed tension on facing sheet – N
- $f_{C_c,k}$  = characteristic adhesive strength in tension of wool core – N/mm<sup>2</sup>  
(from Table 15)
- $A_s$  = area of the stiff support area – mm<sup>2</sup>, support width  $a \geq 60$  mm
- $B$  = support circuit – mm
- $e$  = tested dimension, dependant on panel type – mm
- $k$  = tested coefficient for durability [1.5]
- $\gamma_M$  = tension material safety coefficient, [1.33]
- $\gamma_F$  = safety coefficient for load, [1.5]

**Table 15.** Characteristic adhesive strength in tension of wool core  $f_{C_c,k}$  and e-dimensions for different panel types.

Panel type	AST® L	AST® S	AST® E
$f_{C_c,k}$	0.110 N/mm <sup>2</sup>	0.130 N/mm <sup>2</sup>	0.230 N/mm <sup>2</sup>
e-dimension	50 mm	40 mm	20 mm

At the same time, the following condition must be applied to the compression force:

$$F_{p,all} = f_{C_c,k} \times A_s / (\gamma_M \times \gamma_F)$$

wherein

- $F_{p,all}$  = allowed compression on facing sheet, N
- $f_{C_c,k}$  = characteristic compression resistance of wool core, N/mm<sup>2</sup>  
(from Table 14)
- $A_s$  = stiff support area without extending the compression are, mm<sup>2</sup>
- $\gamma_M$  = compression material safety coefficient, [1.33]
- $\gamma_F$  = safety coefficient for load, [1.5]

### Dimensioning example

The wall panel type chosen is PAROC® Reface™ AST® S. The thickness of the panel is 240 mm, and the thickness of the facing sheets is 0.6. A brick cladding has been chosen for the facing. The brick tiles are suspended vertically from the spacers at c/c 600 mm. The brick tile is 20 mm thick, 1,200 mm long and 600 mm high. The dead weight of the brick tile is 40 kg/m<sup>2</sup>. The spacer bearing height is 25 mm and its width is 20 mm.

The characteristic value of the wind load is  $q_k = 0.77 \text{ kN/m}^2$ . The pressure coefficients are  $C_{p1} = +1.0$  (zone D) for pressure,  $C_{p1} = -1.0$  (zone B) for suction and  $C_{p1} = -1.4$  (zone A) for the corner.

The partial safety coefficient for loads is  $\gamma_F = 1.5$ .

The profile material thickness is  $t \leq 1.5 \text{ mm}$ , so lapped self-tapping screws may be used  $F_{v,all} = 0.5 \text{ kN}$  and  $F_{t,all} = 0.25 \text{ kN}$ .

#### 1. Shear force resulting from suspension

Shear force on one cross spacer  $F_v = 0.4 \text{ kN/m}^2 \times 0.6 \text{ m} = 0.24 \text{ kN/m}$

Number of fixings  $n \geq F_v / F_{v,all} = 0.24 \text{ kN/m} / 0.5 \text{ kN} = 0.48 \text{ ruuvia/m}$

#### 2. Tension resulting from wind suction and eccentricity of load

Wind suction  $F_{T,w} = -1.0 \times 0.77 \text{ kN/m}^2 \times 0.6 \text{ m} = -0.462 \text{ kN/m}$  (zone B)

Moment affecting spacers, resulting from eccentricity of structure:

$M = (0.020 + (0.5 \times 0.020)) \text{ mm} \times 0.24 \text{ kN/m} = 0.0072 \text{ kNm/m}$ , which yields the following as the tension for the upper spacer:  $F_{Mt} = 0.0072 \text{ kNm/m} / 0.6 \text{ m} = -0.012 \text{ kN/m}$

Number of fixings  $n \geq (F_{T,w} + F_{Mt}) / F_{t,all} = (0.462 \text{ kN/m} + 0.012 \text{ kN/m}) / 0.25 \text{ kN} = 1.89 \text{ screws per m}$

Similarly, the effect of wind in the corner is:

Wind suction  $F_t = -1.4 \times 0.77 \text{ kN/m}^2 \times 0.6 \text{ m} = -0.65 \text{ kN/m}$  (zone A)

Number of fixings  $(F_{t,w} + F_{Mt}) / F_{t,all} = (0.65 \text{ kN/m} + 0.012 \text{ kN/m}) / 0.25 \text{ kN} = 2.63 \text{ screws per m}$

#### 3. Compression resulting from wind pressure and eccentricity of load

Wind pressure  $F_{P,w} = +1.0 \times 0.77 \text{ kN/m}^2 \times 0.6 \text{ m} = +0.462 \text{ kN/m}$  (zone D)

Moment resulting from eccentricity of structure on spacers:  $F_{Mp} = -F_{Mt} = +0.012 \text{ kN/m}$

$F_p = (F_{P,w} + F_{Mp}) = (0.462 \text{ kN/m} + 0.012 \text{ kN/m}) = 0.474 \text{ kN/m} = 382 \text{ N/m}$

The allowed compression for a spacer which is 25 mm wide (a) is calculated as follows::

$$F_{p,all} = f_{C_c,k} \times (A_s + B \times e) / (\gamma_M \times \gamma_F)$$

As the support width  $a \leq 60 \text{ mm}$ , the E-dimension from Table 14 for the panel type AST® S must be reduced as follows::

$$e = k_e \times 40 \text{ mm, wherein } k_e = 1 - (60 - a)/60 = 1 - (60 - 25)/60 = 0.417$$

$$e = 0.417 \times 40 \text{ mm} = 16 \text{ mm}$$

Allowed compression  $F_{p,all} = 0.060 \text{ N/mm}^2 \times (25 \text{ mm} \times 1000 \text{ mm} + 2 \times 1000 \text{ mm} \times 16 \text{ mm}) / (1.33 \times 1.5) = 1714 \text{ N/m}$ , which is greater than  $F_p = 474 \text{ N/m}$ .

Next, the combined effect of the share, tension and compression should be checked. The distribution of the fixings can be determined by adding together the number of fixings required for the share and tension forces:

In the wind zone B:

$n \geq (0.48 + 1.89)$  screws per m = 2.37 screws per m, so the distance between fixings  $s \leq 422$  mm,  $s = 400$  mm is chosen.

In the wind zone A:

$n \geq (0.48 + 2.63)$  screws per m = 3.11 screws per m, so the distance between fixings  $s \leq 320$  mm,  $s = 300$  mm is chosen.

#### 4. Tensile and shear force both affect the screw fixing simultaneously (EN 1993-1-3)

In the wind zone B:

$$(F_t/F_{t,all}) + (F_v/F_{v,all}) = (400/1000 \times 0.474 \text{ kN}/0.25 \text{ kN}) + (400/1000 \times 0.24 \text{ kN}/0.5 \text{ kN}) = 1.004 \approx 1.0$$

In the wind zone A:

$$(F_t/F_{t,all}) + (F_v/F_{v,all}) = (300/1000 \times 0.76 \text{ kN}/0.25 \text{ kN}) + (300/1000 \times 0.24 \text{ kN}/0.5 \text{ kN}) = 0.93 < 1.0$$

#### 5. Compression and shear force are active simultaneously

$$(F_p/F_{p,all}) + (F_v/F_{v,all}) = (474 \text{ N/m} / 1714 \text{ N/m}) + (400/1000 \times 0.24 \text{ kN}/0.5 \text{ kN}) = 0.47 < 1.0$$

#### 6. One part of the structure is affected by both a tensile and a compression force

In the wind zone B:

$$(F_t/F_{t,all})^2 + (F_p/F_{p,all})^2 = (400/1000 \times 0.474 \text{ kN}/0.25 \text{ kN})^2 + (474 \text{ N/m} / 1714 \text{ N/m})^2 = 0.65 < 1.0$$

In the wind zone A:

$$(F_t/F_{t,all})^2 + (F_p/F_{p,all})^2 = (300/1000 \times 0.662 \text{ kN}/0.25 \text{ kN})^2 + (474 \text{ N/m} / 1714 \text{ N/m})^2 = 0.71 < 1.0$$

Therefore, the brick cladding may be installed with the spacer distribution  $c/c$  600, fixing spacing  $s = 400$  mm in wind zone B and  $s = 300$  mm in wind zone A.

No effects of structural moisture, ice or accumulated snow have been taken into account when determining the loads.

Any temperature differences between the wall panel and the spacer structures of the brick tile have been estimated as relatively minor.

When the length of the mounting beam is 2.4 m and  $dT < 70$  °C (−30 °C in winter and +40 °C in summer), the total length change is  $dL = \alpha \times dT \times L = 1.2 \times 10^{-5} \times 70$  °C  $\times$  2,400 mm = 2.0 mm. The elongated mounting holes in the mounting beam allow for some movement. Temperature changes do not result in any extra strain on screw fixings.

## 4 APPROVALS AND CERTIFICATES

The properties of PAROC® Reface™ panels are subject to ongoing monitoring through Paroc Panel System's own quality control as well as quality control by official bodies. Det Norske Veritas has granted Paroc Panel System an ISO 9001 quality certificate.

The entire production chain from choosing suitable materials to customer deliveries is governed by a strict quality system. Paroc Panel System also holds an optional product certificate for the PAROC® Reface™ panel, granted by VTT.



# PAROC PANEL SYSTEM – EXPERIENCE SINCE 1986

PAROC sandwich panels are steel-faced light-weight panels with a stone wool core used in public, commercial and industrial construction.



## PRODUCTS

Paroc Panel System manufactures steel-faced, stone wool sandwich panels for façades, partition walls and ceilings. The panels are safe, light-weight and easy to install, as well as aesthetically pleasing. They help refinish façades in no time. PAROC panels have many exceptional properties: they are non-combustible, strong, heat-insulating and airtight.



## COMPETENCE

The high quality of our products is made possible by our knowledgeable and committed staff. We offer customer-focused solutions that are safe, functional and stylish. We provide added value to our partners by maintaining a successful and inspiring atmosphere where people are focused on development and professional knowledge. Our goal is to remain the number 1 supplier of stone wool core sandwich panels.

## SALES AND PRODUCTION

Our international sales and distribution network covers most of Europe and the Middle East. Northern Europe is our main market. Our extensive experience and reliability as a partner have secured us the position of number 1 supplier in Nordic countries. PAROC panels are manufactured in Parainen, Finland.



The information in this brochure is an exclusive and full description of the product properties. The description is valid from the time this brochure is drafted until it is replaced by a new electronic or printed description. The latest version of the description will always be accessible on the Paroc website. The brochure material is intended to present product solutions and applications that are within the scope of the functionality and the technical properties of the products. The contents of this brochure do not constitute a warranty of any kind. We will not be liable for any use of our products in conjunction with the use or installation of third party products or solutions. We will not be liable for any use of the product for purposes other than those defined in this brochure. We reserve the right to modify or change our brochures.

August 2017  
Replaces: April 2017

**PAROC PANEL SYSTEM OY AB**  
Sysilähden teollisuusalue 2  
21600 Parainen  
Phone +358 (0)46 876 8000  
panelinfo@paroc.com  
www.paroc.com/panelsystem